

### Specification

Nominal Voltage	12V		
Nominal Capacity(10hrs rate)	120.0AH		
Dimension	Length	410±3mm(16.14 inches)	
	Width	177±2mm(6.97 inches)	
	Container Height	225±2mm(8.86 inches)	
	Total Height (with Terminal)	225±2mm(8.86 inches)	
	Approx Weight	Approx 37.6 Kg (82.9 lbs)	
Design Float Life	12 years at 25°C(77°F)		
Container Material	ABS		
Rated Capacity	128.4AH/6.42A	(20hr, 1.80V/cell, 25°C/77°F)	
	120.0AH/12.0A	(10hr, 1.80V/cell, 25°C/77°F)	
	104.4AH/20.88A	(5hr, 1.75V/cell, 25°C/77°F)	
	93.6AH/31.2A	(3hr, 1.75V/cell, 25°C/77°F)	
	74.4AH/74.4A	(1hr, 1.60V/cell, 25°C/77°F)	
Max. Discharge Current	1300A (5s)		
Internal Resistance	Approx 3.7mΩ		
Operating Temp. Range	Discharge :	-15~50°C (5~120°F)	
	Charge :	0~40°C (5~104°F)	
	Storage :	-15~40°C (5~104°F)	
Nominal Operating Temp. Range	25±3°C (77±5°F)		
Cycle Use	Initial Charging Current less than 36.0A. Voltage		
	14.4V~15.0V at 25°C(77°F)Temp. Coefficient -30mV/°C		
Standby Use	No limit on Initial Charging Current Voltage		
	13.5V~13.8V at 25°C(77°F)Temp. Coefficient -20mV/°C		
Capacity affected by Temperature	40°C (104°F)	103%	
	25°C (77°F)	100%	
	0°C (32°F)	86%	
Self Discharge	≤1.5% per month		
	RUZET LPA series batteries may be stored for up to 6 months at 25°C(77°F) and then a freshening charge is required.		

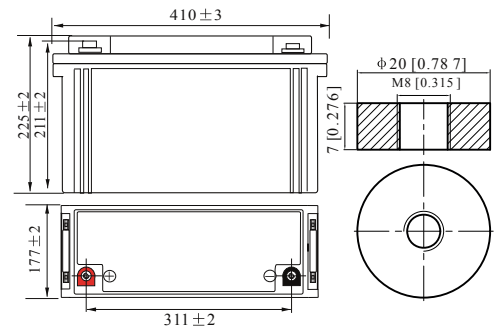

■ Terminal  
Unit: mm [inches]



### Applications

- UPS and EPS
- Emergency light
- Railway signal and aircraft signal system
- Marine and power stations Alarm and security system
- Electronic apparatus and equipment
- Communication power supply, DC power supply

### Constant Current Discharge (Amperes) at 25°C (77°F)

F.V/Time	10 min	15 min	20 min	30 min	45 min	1h	2h	3h	4h	5h	6h	8h	10h	20h
1.85V/cell	140.4	118.1	104.8	86.9	67.0	57.4	37.1	27.9	22.9	19.2	16.9	13.5	11.6	6.20
1.80V/cell	160.7	132.6	115.8	94.4	72.3	60.5	39.9	30.0	24.3	20.4	17.9	14.2	12.0	6.42
1.75V/cell	182.5	149.4	128.0	102.5	78.9	66.0	41.5	31.2	25.2	20.9	18.4	14.7	12.3	6.58
1.70V/cell	206.1	165.8	141.3	112.0	85.0	69.8	43.7	32.8	26.3	22.1	19.3	15.3	12.8	6.75
1.65V/cell	221.3	177.5	150.3	118.1	89.9	72.2	45.3	34.2	27.3	22.8	20.0	15.9	13.2	6.96
1.60V/cell	243.5	194.4	163.3	126.1	93.4	74.4	46.5	35.0	27.9	23.3	20.4	16.1	13.4	7.07

### Constant Power Discharge (Watts) at 25°C (77°F)

F.V/Time	10 min	15 min	20 min	30 min	45 min	1h	2h	3h	4h	5h	6h	8h	10h	20h
1.85V/cell	262.2	222.7	199.6	167.3	130.2	111.8	72.9	55.0	45.2	38.1	33.5	27.0	23.2	12.4
1.80V/cell	296.5	246.7	217.4	179.0	139.4	117.4	77.8	58.7	47.8	40.2	35.3	28.3	24.0	12.8
1.75V/cell	331.4	274.7	238.0	192.9	150.6	127.4	80.6	60.9	49.3	41.0	36.3	29.2	24.6	13.1
1.70V/cell	365.9	300.6	260.8	209.5	161.6	134.4	84.8	63.9	51.4	43.3	38.0	30.4	25.5	13.5
1.65V/cell	389.4	319.4	275.4	219.2	169.5	138.0	87.4	66.2	53.2	44.5	39.2	31.3	26.2	13.9
1.60V/cell	418.7	344.1	295.9	232.3	175.2	141.4	89.2	67.6	54.2	45.5	39.9	31.8	26.7	14.1