

Specification

Nominal Voltage	12V		
Nominal Capacity(10hrs rate)	150.0AH		
Dimension	Length	485 ± 3mm(19.09 inches)	
	Width	170 ± 2mm(6.69 inches)	
	Container Height	240 ± 2mm(9.45 inches)	
	Total Height (with Terminal)	240 ± 2mm(9.45 inches)	
Approx Weight	Approx 48.2 Kg (106.3 lbs)		
Design Float Life	12 years at 25°C(77°F)		
Container Material	ABS		
Rated Capacity	160.5AH/8.03A	(20hr, 1.80V/cell, 25°C/77°F)	
	150.0AH/15.0A	(10hr, 1.80V/cell, 25°C/77°F)	
	130.5AH/26.1A	(5hr, 1.75V/cell, 25°C/77°F)	
	117.0AH/39.0A	(3hr, 1.75V/cell, 25°C/77°F)	
Max. Discharge Current	93.0AH/93.0A	(1hr, 1.60V/cell, 25°C/77°F)	
	1500A (5s)		
Internal Resistance	Approx 3.7mΩ		
Operating Temp. Range	Discharge :	-15~50°C (5~120°F)	
	Charge :	0~40°C (5~104°F)	
	Storage :	-15~40°C (5~104°F)	
Nominal Operating Temp. Range	25 ± 3°C (77 ± 5°F)		
Cycle Use	Initial Charging Current less than 45.0A. Voltage		
	14.4V~15.0V at 25°C(77°F)Temp. Coefficient -30mV/°C		
Standby Use	No limit on Initial Charging Current Voltage		
	13.5V~13.8V at 25°C(77°F)Temp. Coefficient -20mV/°C		
Capacity affected by Temperature	40°C (104°F)	103%	
	25°C (77°F)	100%	
	0°C (32°F)	86%	
Self Discharge	≤1.5% per month		
	RUZET LPA series batteries may be stored for up to 6 months at 25°C(77°F) and then a freshening charge is required.		

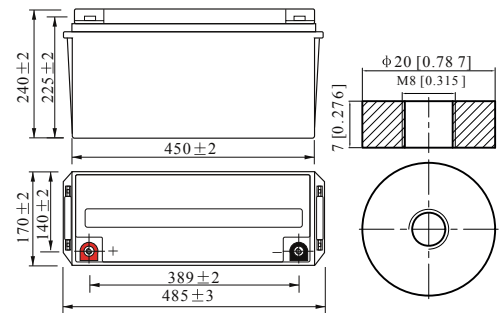

■ Terminal
Unit: mm [inches]



Applications

- UPS and EPS
- Emergency light
- Railway signal and aircraft signal system
- Marine and power stations Alarm and security system
- Electronic apparatus and equipment
- Communication power supply, DC power supply

Constant Current Discharge (Amperes) at 25°C (77°F)

F.V/Time	10 min	15 min	20 min	30 min	45 min	1h	2h	3h	4h	5h	6h	8h	10h	20h
1.85V/cell	175.5	147.6	131.0	108.6	83.8	71.7	46.4	34.9	28.6	24.1	21.1	16.9	14.5	7.76
1.80V/cell	200.8	165.7	144.8	118.0	90.4	75.7	49.9	37.5	30.4	25.5	22.3	17.8	15.0	8.03
1.75V/cell	228.1	186.8	160.0	128.2	98.6	82.5	51.9	39.0	31.4	26.1	23.0	18.4	15.4	8.23
1.70V/cell	257.6	207.3	176.6	139.9	106.2	87.3	54.7	41.1	32.9	27.6	24.1	19.2	16.0	8.44
1.65V/cell	276.6	221.9	187.9	147.7	112.4	90.3	56.7	42.7	34.1	28.5	25.0	19.8	16.4	8.70
1.60V/cell	304.3	243.0	204.1	157.6	116.8	93.0	58.1	43.8	34.9	29.2	25.5	20.2	16.8	8.84

Constant Power Discharge (Watts) at 25°C (77°F)

F.V/Time	10 min	15 min	20 min	30 min	45 min	1h	2h	3h	4h	5h	6h	8h	10h	20h
1.85V/cell	327.7	278.4	249.5	209.2	162.8	139.7	91.1	68.7	56.5	47.6	41.9	33.7	29.1	15.5
1.80V/cell	370.6	308.4	271.8	223.7	174.2	146.7	97.3	73.4	59.7	50.3	44.2	35.4	29.9	16.0
1.75V/cell	414.2	343.4	297.5	241.1	188.2	159.2	100.8	76.1	61.6	51.3	45.4	36.5	30.7	16.4
1.70V/cell	457.4	375.7	326.0	261.8	202.0	167.9	105.9	79.9	64.2	54.1	47.5	38.0	31.9	16.8
1.65V/cell	486.7	399.2	344.2	274.1	211.9	172.5	109.2	82.8	66.5	55.7	49.0	39.2	32.7	17.3
1.60V/cell	523.4	430.1	369.9	290.4	219.0	176.7	111.4	84.5	67.8	56.8	49.9	39.8	33.3	17.6